

# Operating Instructions – Oven Whirlpool AKZ 146/IX

Appliance description

First/Last – Shelf Positions

1. Control Panel
2. Cooling Fan
3. Top heating element
4. Oven Light
5. Round heating element
6. Fan
7. Oven door hinges
8. Oven Door

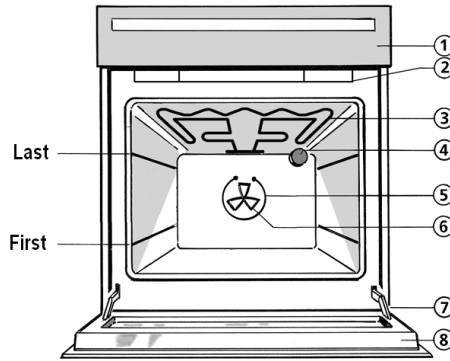

Note: The cooling fan switches on only when the oven has reached a certain temperature with the exception of the Grill Functions where it starts immediately.

1. Selector Knob to choose the oven functions.
2. Button to select and confirm the different operations (operate by single presses only).
3. Knob to set time of day, cooking time, the time at which cooking should terminate, the temperatures and the power levels (Function P).

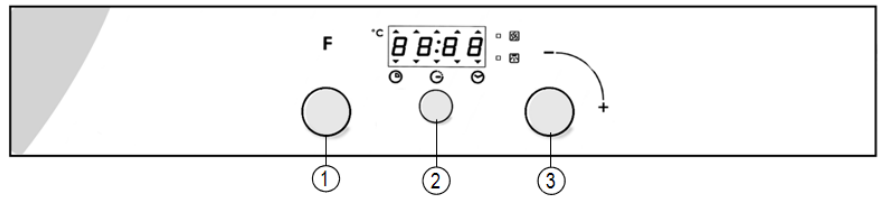

Quick Operation

First check – If the Display on the control panel shows four dashes as below, then all you have to do is select which function you wish to use for the oven using the left hand Dial, then select the temperature setting you require using right hand Dial and the required function will start.



If the display does not read as above: Ensure all controls on the control panel are turned off.

If they are on, Switch OFF the mains supply to the oven located on the wall nearby and wait for a few seconds.





Switch ON the mains power to the oven. The display on the Control Panel should now read STOP.

Press the MIDDLE button under the display once.

- The display should now read the 4 Dashes as shown earlier
- Select the required oven/Grill function from the choices on the left hand dial.
- Select the required temperature using the right hand dial.



### Oven Functions

Function symbol	Function	Preset temperature/ level	Function description
0	Oven off	-	
	Oven light	-	To switch on the oven light.
	MLTF (Heat Maintenance)	35C	To keep a constant temperature, either 35°C or 60°C.
	Fan	160C	To cook on more than one shelf level, at the same temperature.
	Grill	3	To grill small pieces of meat, toast, etc.
	Turbogrill (Grill + Fan)	3	To grill large pieces of meat.

### "MLTF" Function (Heat maintenance)

This function keeps one of two temperature levels of temperature (either 35°C or 60°C) inside the oven.

- Setting the temperature at 35°C is particularly useful to raise dough for bread and pizza.
- The default setting is 35°C. For this function it is advisable to use the first shelf level.
- Use the 60°C temperature setting to keep the food warm once it is cooked.

### Fan function

This function is especially useful for simultaneously cooking different foods at more than one shelf level (for example: fish, vegetables, pasta).

This function allows temperature control; the temperature can be set in the range 50°C to 250°C.

The default setting is 160°C.

- If possible choose dishes that require the same
- It is not necessary to preheat the oven.
- If the dishes in the oven have different cooking times, remove completed dishes and leave remaining foods until cooked.

### Grill function

This function is ideal to grill small pieces of meat (steaks, sausages) and for making toast.

This function allows four slight adjustments which progressively increase heat output (position 1, 2, 3, 4) plus a maximum heat setting (position 5) for the upper heating element. The default setting is 3.

- Preheat the oven for 3/5 minutes with the oven door closed
- The oven door should remain open during grilling for best cooking performance but may be closed if preferred
- When cooking meat, to avoid spatters of fat and smoke, pour a little water into the drip tray.
- Turn the food half-way through grilling time.

### Turbo grill function (Grill + Fan)

This function is ideal to cook large chunks of meat (i.e. roast beef, roasts).

This function allows four slight adjustments which progressively increase heat output (position 1, 2, 3, 4) plus a maximum heat setting (position 5) for the upper heating element. The default setting is 3.

- Keep the oven door closed while cooking
- Lay the meat onto the grid and position the drip tray on the first shelf level. To avoid spatters of fat and smoke, pour a little water into the drip tray.
- Turn over the meat half-way through cooking time.